

"WE MAKE THE KITCHEN BETTER!"

36" Infrared Salamander Broiler

(Range Mount)

Standard Features

- Stainless steel exterior and interior
- Dual valve controls for left and right side independent operation
- Two (2) 21,500 BTU high efficiency ceramic infrared burners and standby pilots – totals 43,000 BTU
- 1 minute pre-heat time
- 4 position rack adjustments
- One (1) removable broiler chrome rack
- Removable crumb/grease tray
- Range mount kit ships with salamander broiler
- NOTE: Range mount is only compatible with an Atosa 36" range

Optional Accessories

- Wall mount kit 21208001048

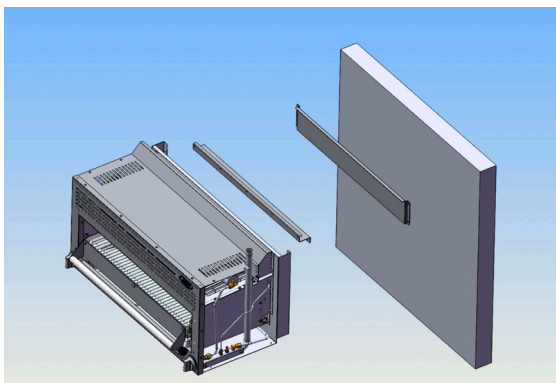

MODELS:

ATSB-36



1 YEAR PARTS AND LABOR WARRANTY (US ONLY)



Conforms to ANSI
STD Z83.11-2009 (2011)
Certified for CSA
STD 1.4B-2009 (2011)
Conforms to NSF/ANSI STD.4



REV. 08/24

"WE MAKE THE KITCHEN BETTER!"

SPECIFICATIONS

Model	Burners and Control Method	Gas Type	Intake-tube Pressusre (in.W.C.)	Per BTU B.T.U./h	Total BTU B.T.U./h	Regulator	Exterior Dimensions (inch)	Net Weight (lb)	Gross Weight (lb)
ATSB-36	2 Burners Independent Manual Control	NG	5	21,500	43,000	5" w.c.	36×18×17 ^{1/3}	143	169
		LP	10	21,500	43,000	10" w.c.			

PLAN VIEW

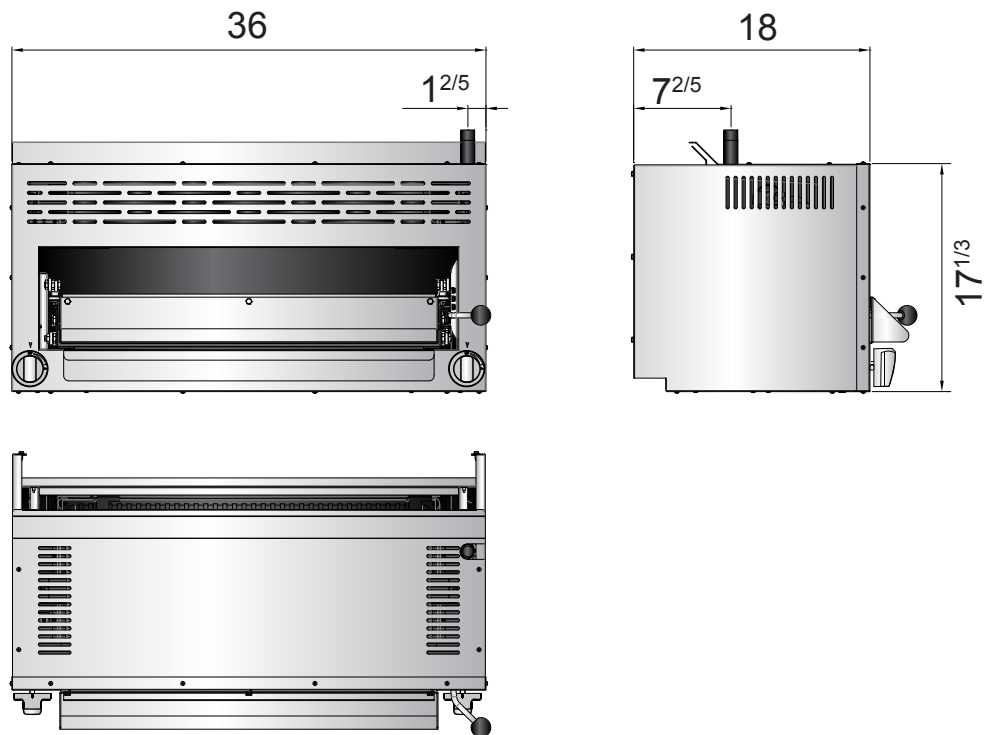

Stainless steel exterior



Crumb/grease tray



Stainless steel knobs



Broiler chrom rack



4 position controller

