

GP-ME-2PS-18

Gelum
PROFESIONAL

Mesa refrigeradora grande, para preparar ensaladas y emparedados.
Large size refrigerated salads and sandwiches preparation table.



Vista superior / Top view:
Pulg. [mm] / In [mm]:

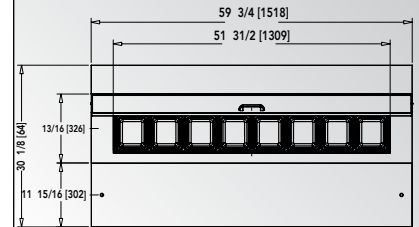

Vista lateral / Side view:
Pulg. [mm] / In [mm]:

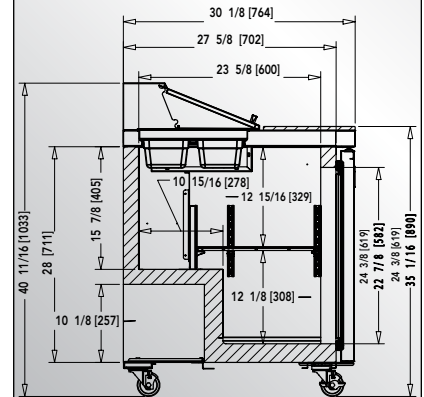

CARACTERÍSTICAS:

- Conveniencia: tapadera de acero inoxidable, con aislante, para mayor eficiencia y conservación de los alimentos.
- Segura y confiable: bandejas refrigeradas para alimentos, para organizar ingredientes, de policarbonato irrompible transparente, con certificación sanitaria NSF.
- Diseñada para mejorar procesos: tabla de poliestireno para cortar, con textura antideslizante y certificación sanitaria NSF.
- Diseño premium y robusto: gabinete exterior, sobremostrador y tope salpicadero en acero inoxidable 430.
- Fondo de tina y pared interior trasera de acero inoxidable 430.
- Paredes interiores laterales de aluminio.
- Control electrónico de temperatura.
- Micromotores electrónicos para menor consumo de energía.
- Rodos.
- Aislante de poliuretano, libre de CFCs, con ciclopentano como agente espumante.

FEATURES

- Convenience: stainless steel insulated lid for improved efficiency and food preservation.
- Safe and reliable: NSF approved refrigerated food pans for ingredients, made with break-resistant clear polycarbonate.
- Improve workflow: NSF approved polystyrene cutting board with anti-slip texture.
- Robust and premium design: 430 stainless steel exterior cabinet, top and splash guard.
- 430 stainless steel interior bottom and interior rear wall.
- Aluminum interior side walls.
- Electronic temperature control.
- Electronic fan motors for maximum energy efficiency
- Casters.
- CFC-free polyurethane insulation with cyclopentane as the blowing agent.

DIMENSIONS DIMENSIONES			CAPACITY* CAPACIDAD*		SHIPPING ENVÍO	TECHNICAL INFORMATION INFORMACIÓN TÉCNICA					
Height Alto	Width Frente	Depth Fondo	Cubic ft / lt. Pies3 / lts.	Shelves Parrillas	40' / 45' - container Contenedor de 40' / 45'	Temperature Temperatura	HP	Weight Kg (Net/Gross) Peso Kg (Neto/Bruto)	Refrigerant Refrigerante	Voltage Voltaje	Pans Bandejas
40 5/8 1,033	59 3/4 1,518	30 1/8 764	17.5 / 495	2	28 / 32	34°F - 39°F +1°C - +4°C	1/3	152 / 168	R 290	115V/60Hz/1	16