

# Specification

## HPC7008UC-C9S1



### Non-Insulated Heater Proofer

- ◆ Designed for proofing and heating.
- ◆ All digital display and controls.
- ◆ Machined Zinc Alloy handle.
- ◆ Adjustable thermostat for a variety of warming temperatures.
- ◆ Holding temperature up to 185 F.
- ◆ Water pan provides moisture for proofing.
- ◆ Humidity up to 95% (under 90F).
- ◆ Adjustable & Universal Rack System. Pan capacity is 9 story 18" x26".
- ◆ Clear polycarbonate door for easy viewing.
- ◆ High quality 5" casters, two with safety-lock.
- ◆ Aluminum cabinet.



Note: Dimensions and Specification are subject to change without notice.



This 31" under counter heater proofer, is energy efficient, space savings, ADA compliant cabinet, ideal when space is a concern. Featuring a universal and adjustable pan rack system. Offering the ability to proof a variety of baked goods, allowing dough to rise before baking. All digital temperature controls with easy set up. Enables a variety of temperatures, including warming. Designed with enduring quality in mind.

# Dimensions and Specifications

HPC7008UC-C9S1



Front View

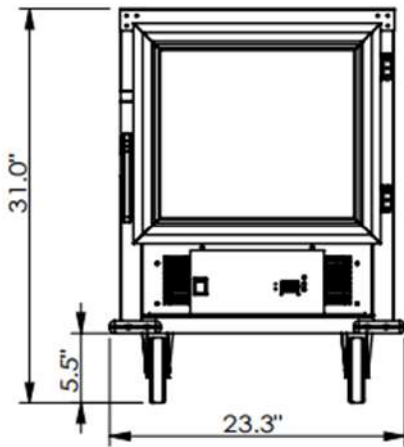

Side View

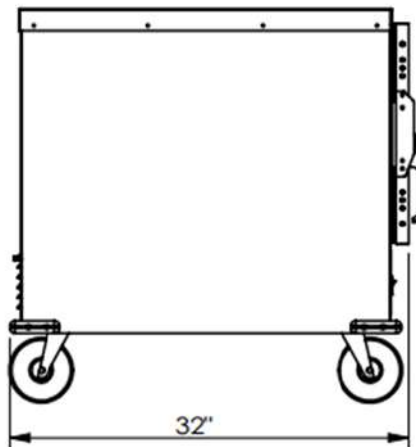

Top View

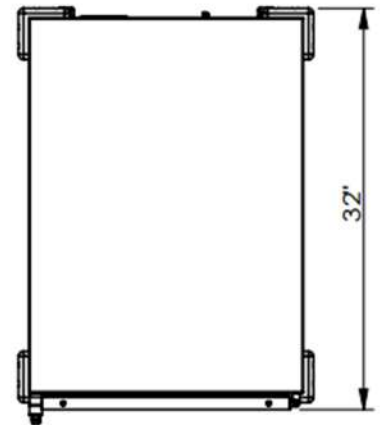

**Pan Capacity** 9 story, 18" x26" in 1-1/2" Increments.

**Electrical** 120 Volts

**Power** 1500 Watts

**Net Weight** 65 lbs.

**Gross shipping weight** 75 lbs.

**Class** 100

**Dimensions** 23.3" W x 32" D x 31" H

**Package** 24" W x 33" D x 32" H

**Warranty** 1 Year Manufactures limited Warranty